

MODEL PREDICTIVE INTEGRATED POWER QUALITY CONTROLLER FOR MICROGRID

S.Manikandan¹

¹PG student,

Department of Electrical and Electronics Engineering,

Dr. M. G. R. Educational & Research Institute, Maduravoyal, Chennai - 95

Mail.Id: srimani_new@yahoo.com

Mr. Chunchu Rambabu²

²Associate Professor,

Department of Electrical and Electronics Engineering,

Dr. M. G. R. Educational & Research Institute, Maduravoyal, Chennai - 95

Abstract-Model predictive control (MPC) concepts applied in novel variable reactor for developing integrated power quality controller (IPQC) using magnetic flux control is proposed for improving power quality in a microgrid such as the harmonic high penetration, frequent voltage fluctuation and over current phenomenon, For the fundamental, the equivalent impedance of the primary winding is a variable reactor. MPC is applied into IPQC to regulate the supply current and the load voltage to the desired reference signals in spite of the existence of harmonic distortions in the supply voltage and the load current, possible sags or swells in the supply voltage, and variations in the load current. The design of the MPC controller is subsequently analyzed in details. The simulation studies are finally presented to verify the performance of MPC.

Keywords-Microgrid, distributed generation, inverter, over current power quality, model predictive control

1. Introduction

The power supply of high quality and reliability is required for the instruments and devices used in manufacture, integration and testing, especially electrical performance measurement and test of the spacecraft, and thereby power distribution systems that can supply excellent power quality are needed for aerospace manufacturing enterprises and research institutes. However, the increasing uses of power electronics in industrial production and people's daily life bring numerous harmonics and disturbances into power networks, and generate kinds of power quality problems in power distribution systems such as voltage and current harmonic distortions, voltage sags and/or swells and voltage fluctuations. These problems become more and more complicated and will cause malfunctioning of instruments, apparatus and facilities. So it is necessary to install advanced compensating devices into a power distribution system to satisfy some particular users' high demand.

Model predictive control (MPC) is an advanced method of process control that has been in use in the process industries in chemical plants and oil refineries since the 1980s. In recent years it has also been used in power system balancing models. Model predictive controllers rely on dynamic models of the process, most often linear empirical models obtained by system identification. The main advantage of MPC is the fact that it allows the current timeslot to be optimized, while keeping future timeslots in account. This is achieved by optimizing a finite time-horizon, but only implementing the current timeslot. MPC has the ability to anticipate future events and can take control actions accordingly. PID and LQR controllers do not have this predictive ability. MPC is nearly universally implemented as a digital control, although there is research into achieving faster response times with specially designed analog circuitry.

2. Literature Survey

In this context, in order to maximize the operational efficiency of the distributed energy resources (DERs) and take full advantage of distributed power generation, as an effective means of integrating DERs into the traditional power grid, microgrid is presented, which can enhance the local customer power supply reliability and system performance, reduce the impact on large power grid, and minimize the system losses. Microgrid has good environmental and economical benefits and has attracted more and more attentions of power researchers .in [1]-[6]. However, the power quality problem of microgrid is much more serious than that of the traditional grid because of the intermittency and randomness of DERs, the high penetration between conventional grid and microgrid, the diversity of DERs, load, energy conversion unit, storage, and operating state. Microgrid power quality has the following unique features compared with the conventional power grid [7]-[12].

This paper in [13] shows the application of the model predictive controller (MPC) on Photovoltaic system using quasi-Z-source inverter (QZSI). The QZSI is a cheap, simple, and a single stage approach for PV arrays. Using the MPC, the output current is regulated based on the reference power. Also, the QZSI inductor current and capacitor voltage are manipulated based on the same cost function. The simulation results using MATLAB simulink confirm the effectiveness of this controller and the advantages of the MPC as a simple and powerful method for power electronics converter, where the same controller is used to control both inverter sides (DC-side and AC-side) using the same cost minimization function.

The paper presented in [14] the state space averaged model of a fuel cell – ultracapacitor hybrid structure. The dynamic model predictive control is designed for FC-UC hybrid structure, which maintains load side requirement and voltage across ultra capacitor. The single MPC controller in outer loop is used to find the reference values for fuel cell and ultra capacitor currents which are used as references for inner PI control loop and is practical implementable. Load estimator implemented in simulation is powerful enough to estimate load variation effectively. Future work is aimed to practical implementation of the MPC based controller for FC-UC hybrid combination with proper inner loop control.

3. Existing Method

There must be some losses when the novel variable reactor system with inverter operates normally and the inverter will absorb active power to maintain the DC voltage constant. The dc-link voltage control schematic diagram of the variable reactor is given in fig.1

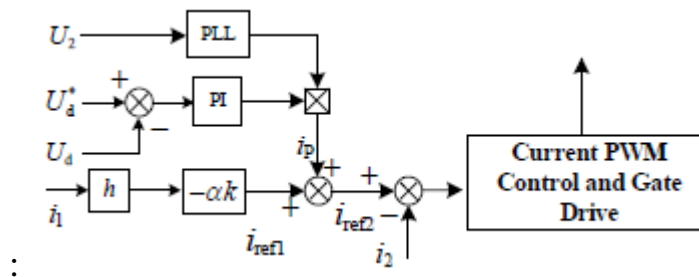

Fig 1. Conventional PI Controller

4. Proposed Method

In proposed we have compare the MPC and the conventional PI controller. MPC we have merits of power flow control, fault current limiter, voltage compensation, harmonic isolation. The novel integrated power quality controller can be installed in series and parallel in microgrid or point of common couplings (PCC) showed in Fig.2. For simplicity, the IPQC is installed in PCC. the three-phase detailed system configuration of the integrated power quality controller with transformer and inverter. U_s and L_s represent the source voltage and impedance of conventional power supply, respectively. The passive filters, which have the function of absorbing the harmonics, are shunted in both sides. U_d is the voltage of DC side of the inverter. The microgrid contains a harmonic load, a Photovoltaic cell system, battery storage system and a normal load. The harmonic load are inject in traditional grid side for first condition and harmonic load are injected in microgrid side in second condition and the THD value for both the case are recorded by using PI controller and MPC.

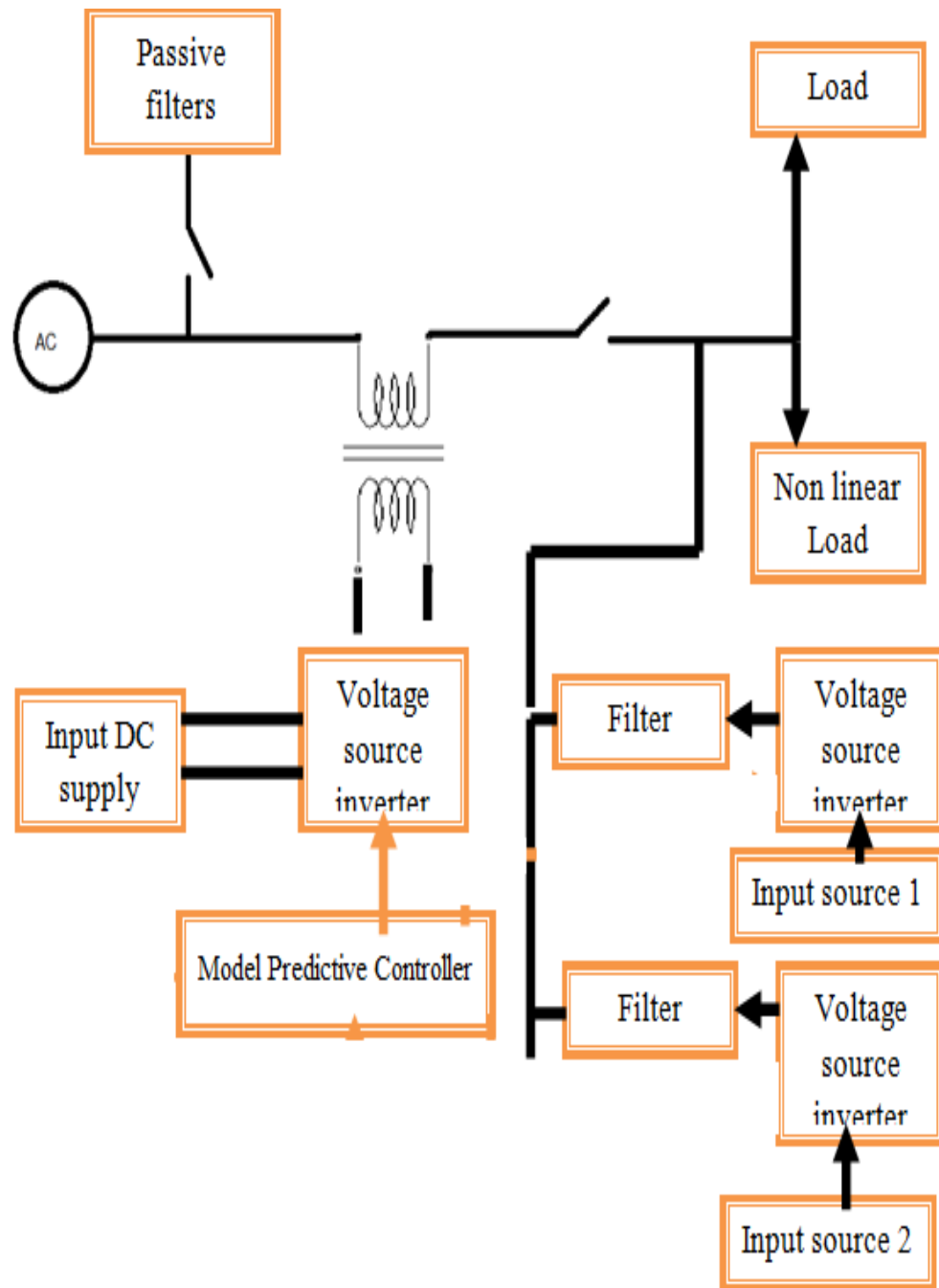

Fig 2. Block diagram of proposed system configuration

5. Simulation Diagram

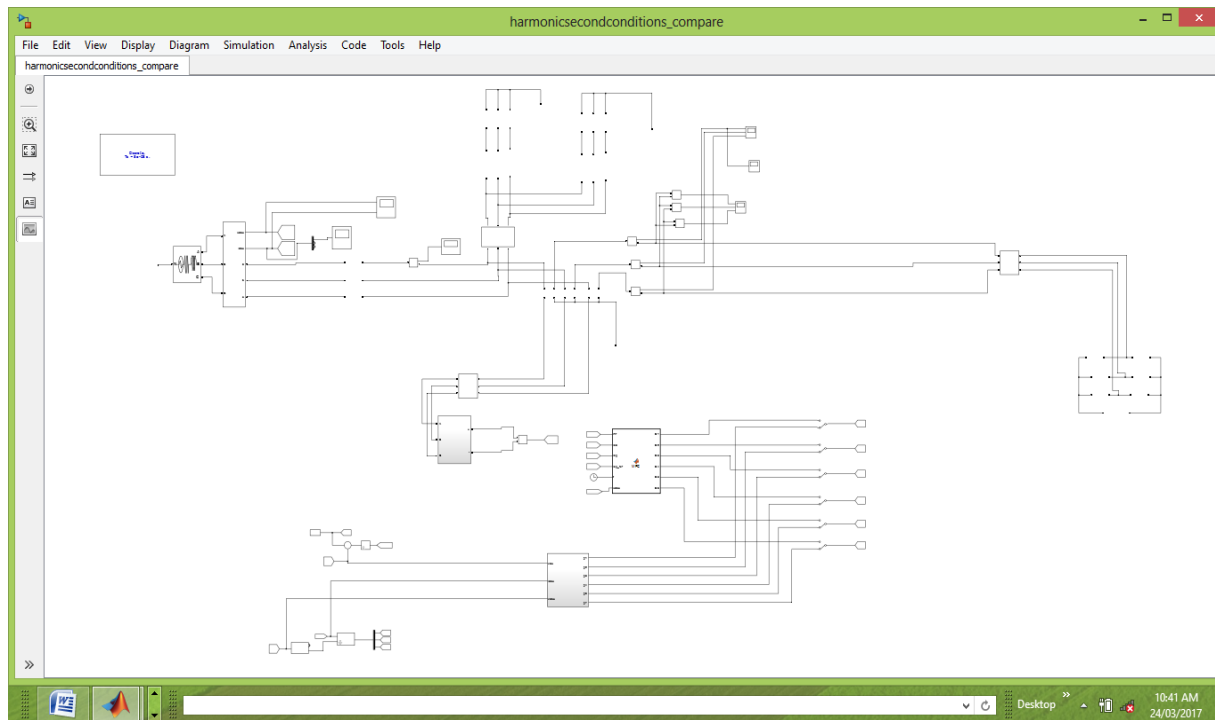
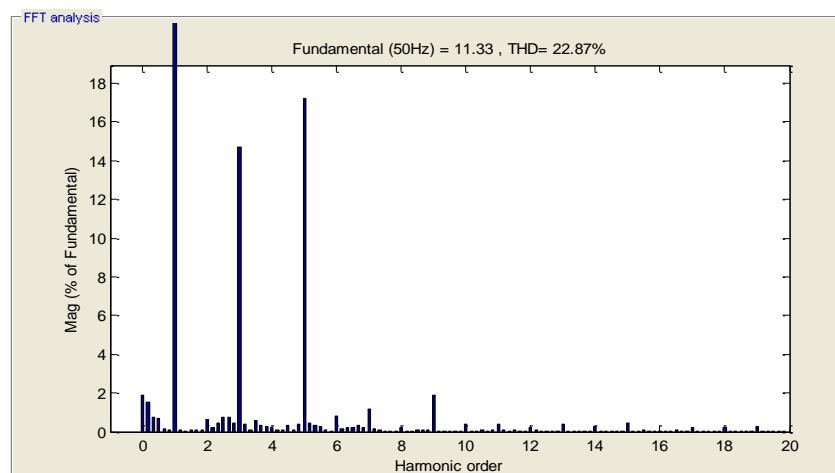

Fig.3 Simulation Diagram of Proposed system with MPC

6. Simulation results

1. Harmonic isolation in **second** condition with PI controller



2. Harmonic isolation in **second** condition with MPC controller

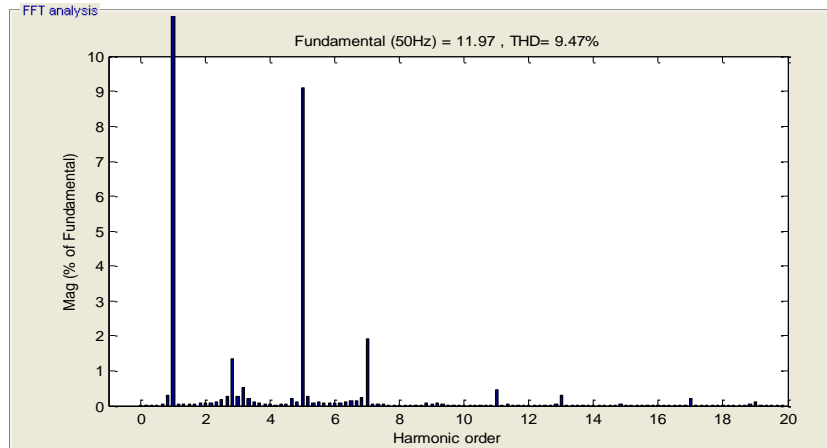

3. Harmonic isolation in **first** condition with MPC controller

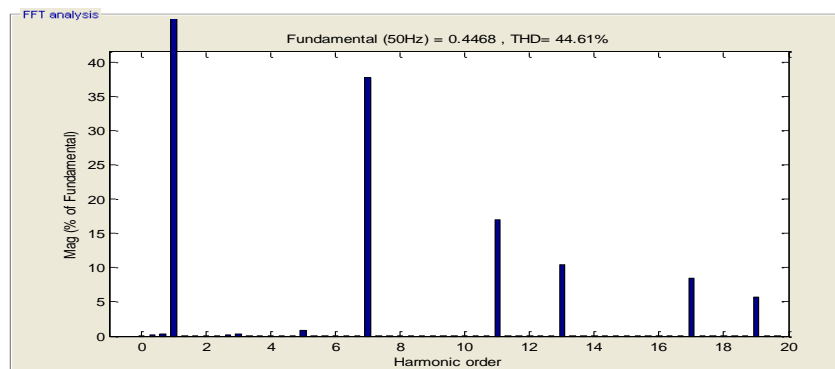

4. Harmonic isolation in **first** condition with PI controller

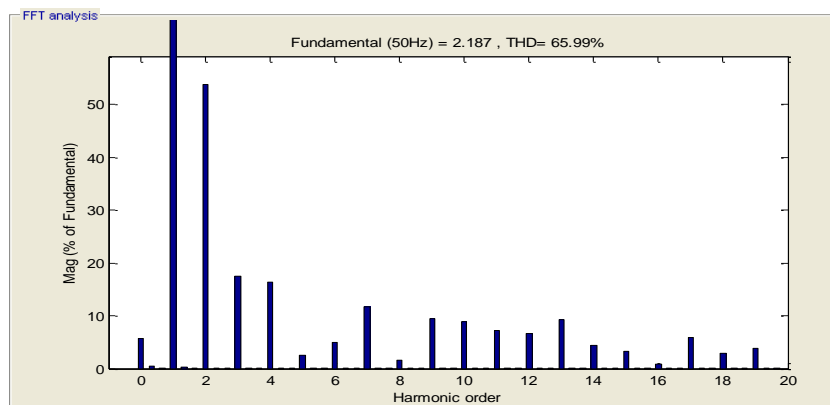

**Table .1 Comparison of conventional PI controller and proposed MPC controller
Harmonics content on first condition and second conditions**

Conditions	Conventional using PI control	Proposed Using MPC control
First	65.99%	44.61%
Second	22.87%	9.47%

7. Conclusion:

The proposed MPC control schemes offers a low THD in second conditions whilst compared with first harmonics conditions. Load based problems gives more power quality issues because of power filters injection can't be meet load balance over source side balance. In this proposed MPC scheme is gives improved harmonics balancing 9.47% in load balancing issues of second harmonics conditions. Proposed controller gives more attention in second case of load harmonics injection. Simulation results were proved using MATLAB / Simulink Results.

References

- [1] C. K. Sao and P. W. Lehn, "Control and power management of converter fed microgrids," IEEE Transactions on Power Systems, vol. 23, no. 3, pp. 1088-1098, Aug. 2008
- [2] Y. Li and Y. W. Li, "Power management of inverter interfaced autonomous microgrid based on virtual frequency-voltage frame," IEEE Transactions on Smart Grid, vol. 2, no. 1, pp. 30-40, Mar. 2011.
- [3] I. J. Balaguer, Q. Lei, S. Yang, U. Supatti, and F. Z. Peng, "Control for grid-connected and intentional islanding operations of distributed power generation," IEEE Transactions on Industrial Electronics, vol. 58, no. 1, pp. 147-157, Jan. 2011.
- [4] J. Rodriguez, and P. Cortes, Predictive Control of Power Converters and Electrical Drives: Wiley, 2012.
- [5] F. Blaabjerg, R. Tedorescu, M. Liserre, and A.V. Timbus, "Overview of control and grid synchronization for distributed power generation systems," IEEE Transactions on Industrial Electronics, vol. 53, no. 5, pp. 1398-1409, Oct. 2006.

- [6] N. Pogaku, M. Prodanovic, and T. C. Green, "Modeling, analysis and testing of autonomous operation of an inverter-based microgrid," *IEEE Transactions on Industrial Electronics*, vol. 22, no. 2, pp. 613-625, Mar. 2007.
- [7] P. Cortez, G. Ortiz, J. I. Yuz, J. Rodriguez, S. Vazquez, and L. G. Franquelo, "Model predictive control of an inverter with output LC filter for UPS applications," *IEEE Transactions on Industrial Electronics*, vol. 56, no. 6, pp. 1875- 1883, Jun. 2009.
- [8] K. S. Low and R. Cao, "Model predictive control of parallel connected inverters for uninterruptible power supplies," in *Proc. Power Electronics Specialist Conf.*, pp. 1-6, Jun. 2006.
- [9] K. S. Low and R. Cao, "Model predictive control of parallel connected inverters for uninterruptible power supplies," *IEEE Transactions on Industrial Electronics*, vol. 55, no. 8, pp. 2884-2893, Aug. 2008.
- [10] U. Ammann, R. Vargas, S. Rees, J. Serra, and J. R. Steilow, "An analytical approach to steady-state current control properties of power converters featuring discrete-time switching," in *Proc. Power Electronics Specialist Conf.*, pp. 2535-2542, Jun. 2008.
- [11] J. Rodriguez, P. Cortez, R. Kennel, and M. P. Kazmierkowski, "Model predictive control – A simple and powerful method to control power converters," in *Proc. Power Electronics and Motion Control Conf.*, pp. 41-49, May 2009.
- [12] N. Arafat, S. Palle, Y. Sozer, and I. Husain, "Transition control strategy between standalone and grid-connected operations of voltage-source inverters," *IEEE Transactions on Industry Applications*, vol. 48, no. 5, pp. 1994-2000, Oct. 2012.
- [13] Ayman F. Ayad, Ralph M. Kennel " Model Predictive Controller for Grid-Connected Photovoltaic based on Quasi-Z-Source Inverter" Technical University of Munich, Munich, Germany.
- [14] Sneha Mane, Pushpak Jagtap, Faruk Kazi, N.M. Singh " Model Predictive Control of Complex switched mode FC-UC Hybrid Structure " 2016 Indian Control Conference (ICC), IIT Hyderabad, Jan 4-6, 2016. Hyderabad, India.